

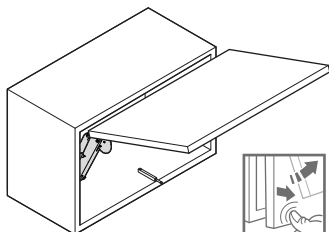

Bedienungsanleitung
Operating instructions
Instruções de montagem

Free space 1.8 push

372.27.xxx



IMPORTANTE:

Ao imprimir o gabarito de furação, certifique-se de preservar o tamanho atual do documento, sem redimensioná-lo.

Após a impressão, meça a escala para checar se está correta, antes de furar.

732.23.206



1



2



4



≥45mm.... 4



5



8



10



11

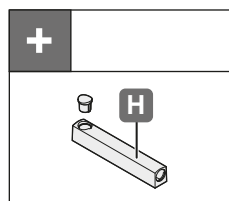
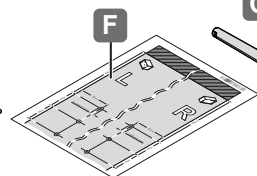
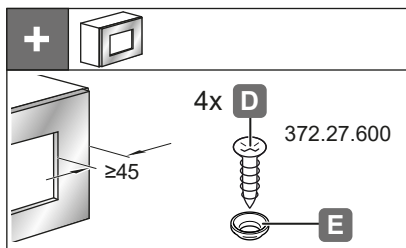
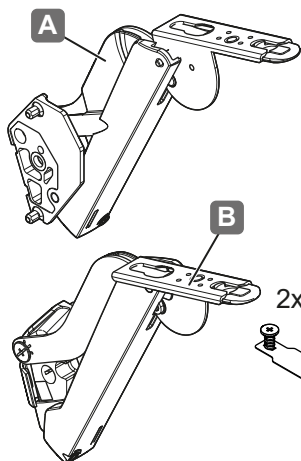

HDE 05.08.2019

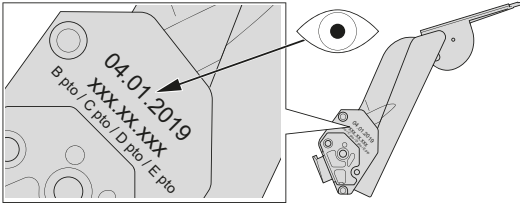

Free space B pto	372.27.705	372.27.505	372.27.355	372.27.305
Free space C pto	372.27.706	372.27.506	372.27.356	372.27.306
Free space D pto	372.27.707	372.27.507	372.27.357	372.27.307
Free space E pto	372.27.708	372.27.508	372.27.358	372.27.308

Free space B pto	372.27.780	372.27.784	372.27.788	372.27.792
Free space C pto	372.27.781	372.27.785	372.27.789	372.27.793
Free space D pto	372.27.782	372.27.786	372.27.790	372.27.794
Free space E pto	372.27.783	372.27.787	372.27.791	372.27.795

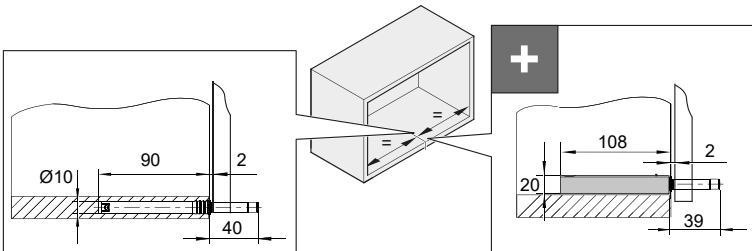
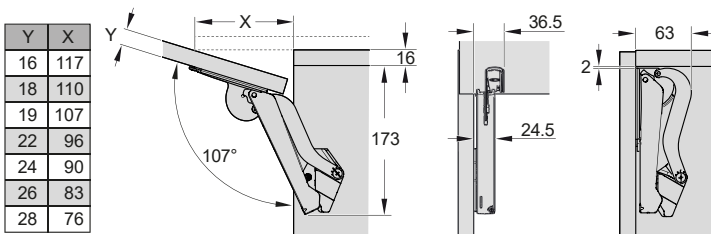



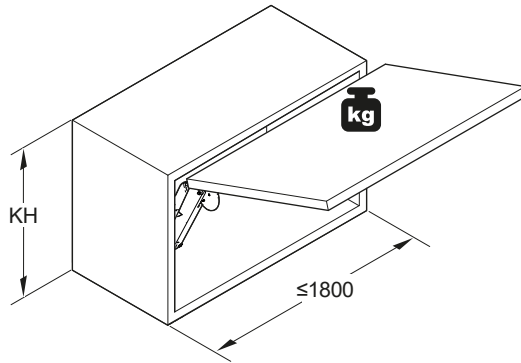

732.23.206

HDE 05.08.2019

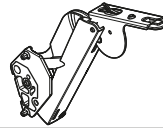

732.23.206



KH	 B pto	 C pto	 D pto	 E pto
225	2,3 – 4,3	3,8 – 7,1	6,4 – 9,3	9,2 – 13,4
250	1,9 – 3,9	3,4 – 6,4	5,8 – 9,1	8,3 – 12,6
275	1,9 – 3,5	3,1 – 5,8	5,3 – 8,2	7,5 – 12,0
300	1,7 – 3,2	2,8 – 5,3	4,8 – 7,5	6,9 – 11,0
325	1,6 – 3,0	2,6 – 4,9	4,4 – 7,0	6,4 – 10,2
350	1,5 – 2,8	2,4 – 4,6	4,1 – 6,5	5,9 – 9,5
375	1,3 – 2,6	2,2 – 4,3	3,8 – 6,0	5,5 – 8,8
400	1,2 – 2,4	2,1 – 4,0	3,6 – 5,6	5,2 – 8,3
425	1,1 – 2,3	2,0 – 3,8	3,4 – 5,3	4,9 – 7,8
450	1,0 – 2,1	1,9 – 3,5	3,2 – 5,0	4,6 – 7,3
475	1,0 – 2,0	1,8 – 3,4	3,0 – 4,7	4,3 – 7,0
500	0,9 – 1,9	1,7 – 3,2	2,9 – 4,5	4,1 – 6,6
525	0,9 – 1,8	1,6 – 3,0	2,7 – 4,3	3,9 – 6,3
550	0,8 – 1,7	1,5 – 2,9	2,6 – 4,1	3,7 – 6,0
575	0,8 – 1,7	1,4 – 2,8	2,5 – 3,9	3,6 – 5,7
600	0,8 – 1,6	1,4 – 2,7	2,4 – 3,7	3,4 – 5,5
625	0,7 – 1,5	1,3 – 2,5	2,3 – 3,6	3,3 – 5,3
650	0,7 – 1,5	1,3 – 2,4	2,2 – 3,5	3,2 – 5,1

HDE 05.08.2019

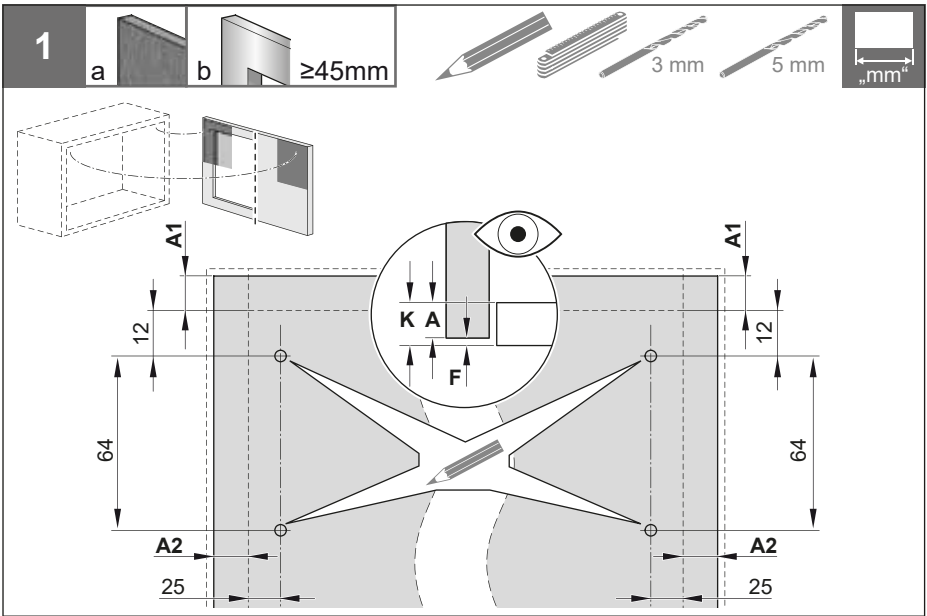

732.23.206

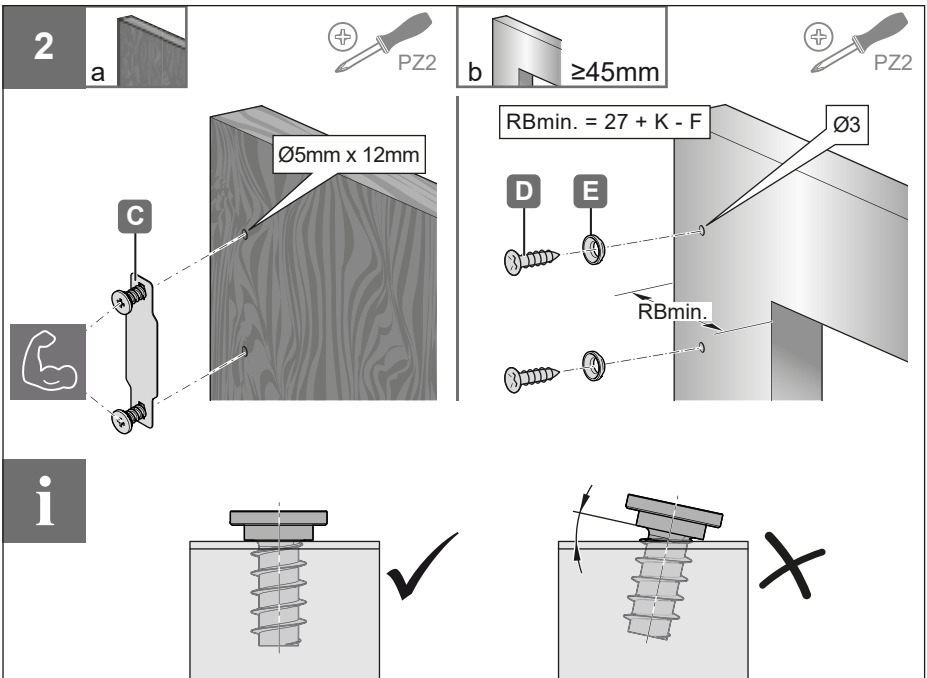

HDE 05.08.2019



3

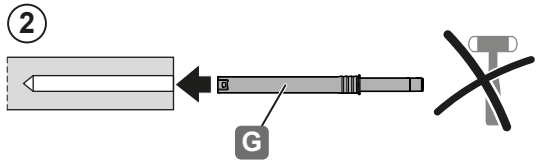
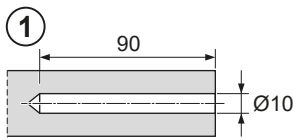
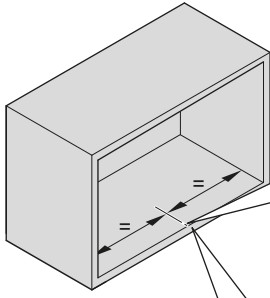
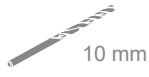
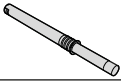

+

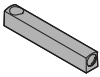

1

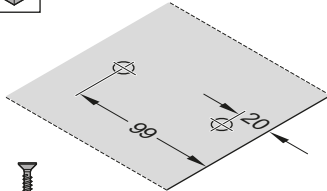

2

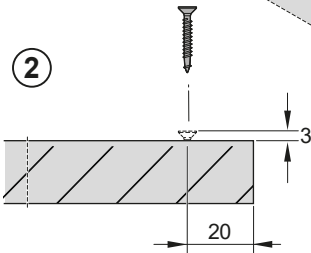

3

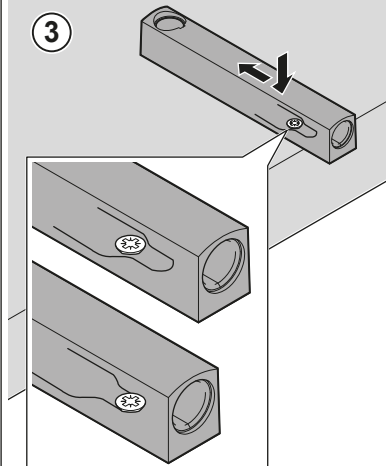

4

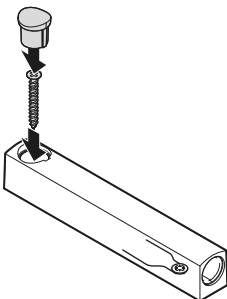

5

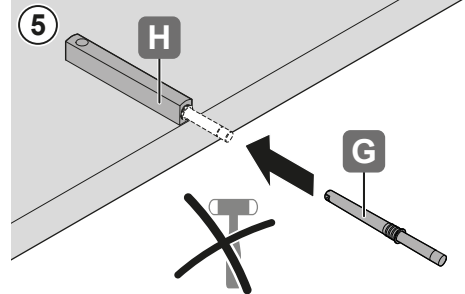

732.23.206

HDE 05.08.2019



4

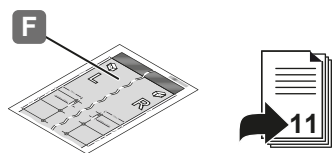
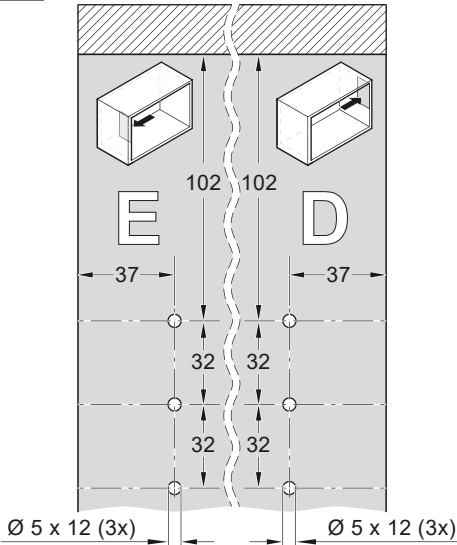
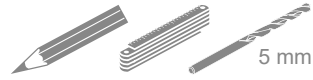

5

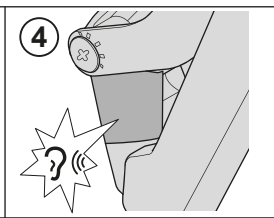
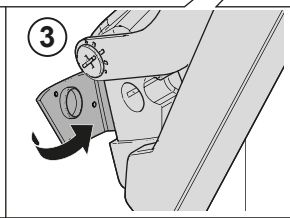
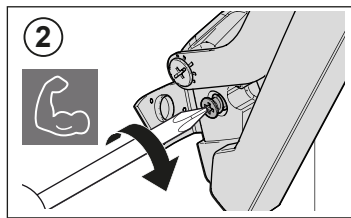
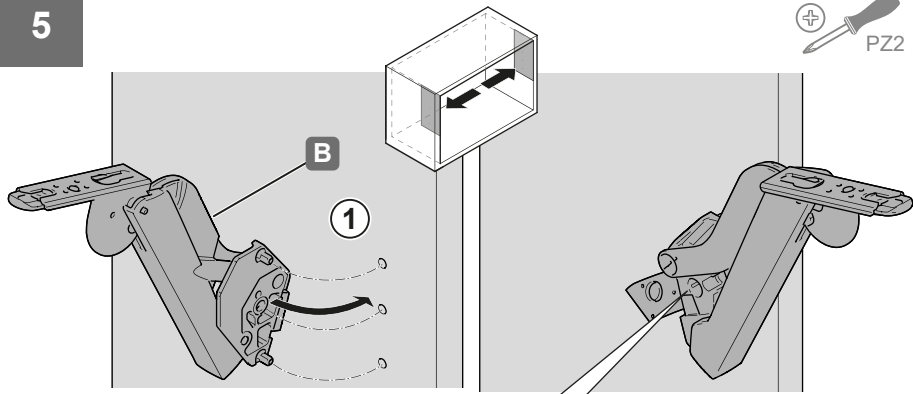



6

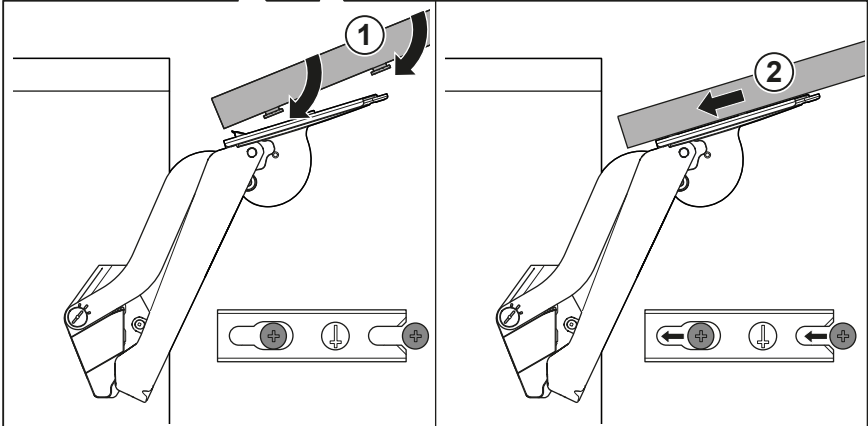
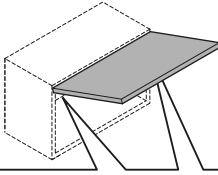

792.23.206

i

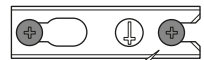
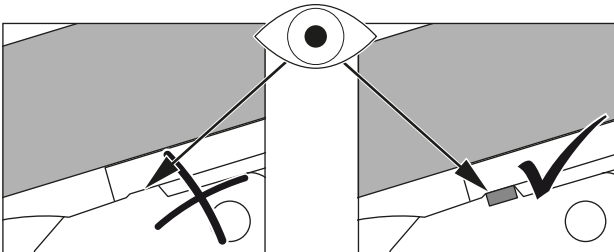
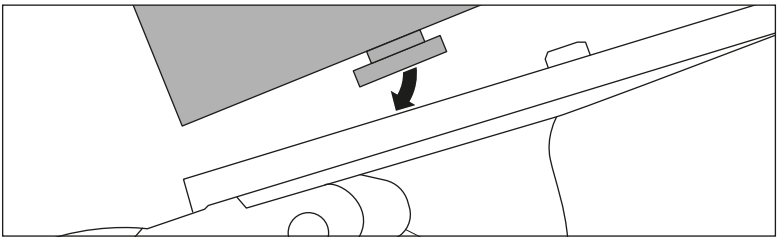

HDE 05.08.2019

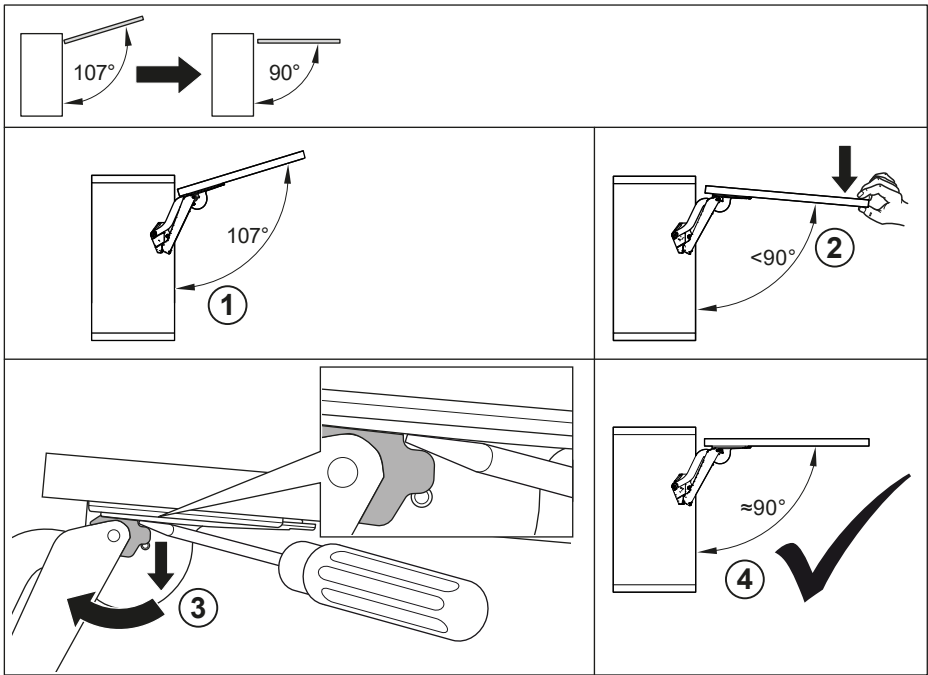

732.23.206

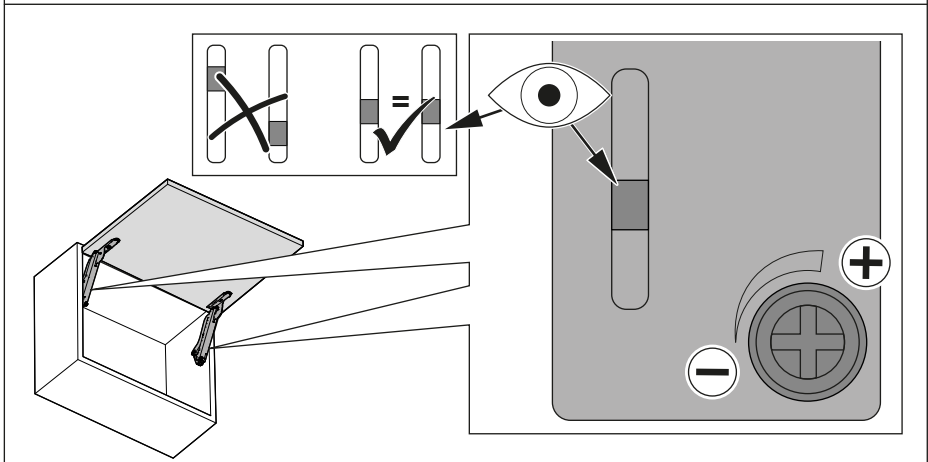
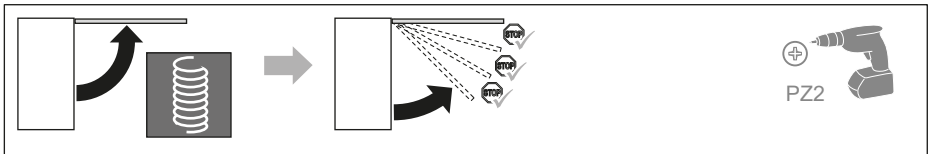

HDE 05.08.2019



732.23.206

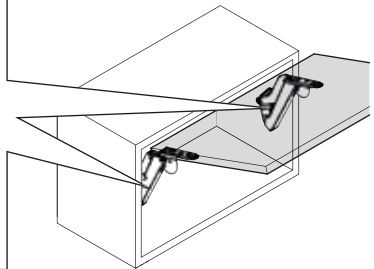
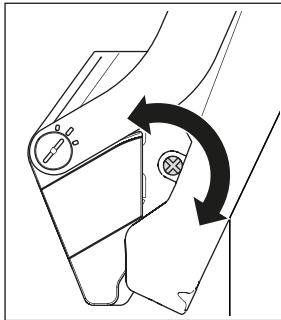
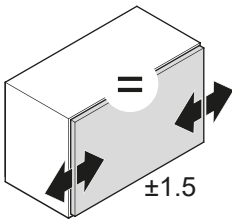
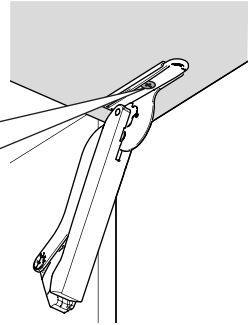
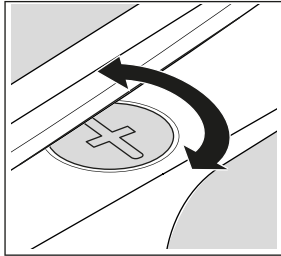
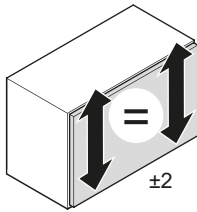
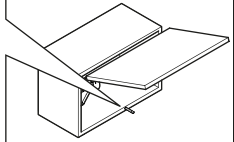
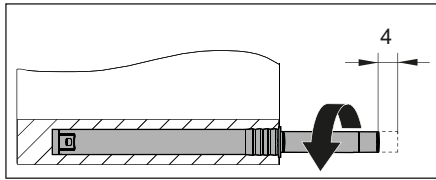
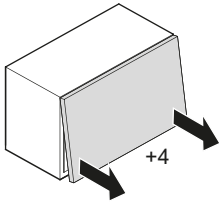

HDE 05.08.2019

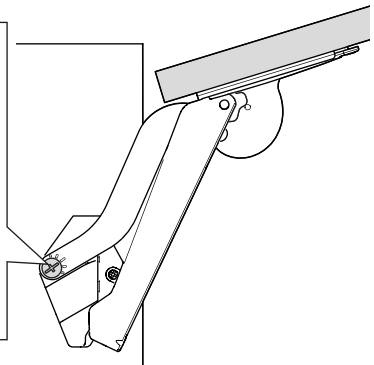
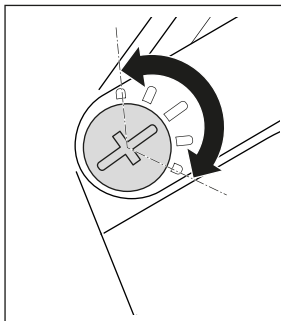
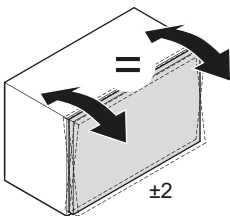

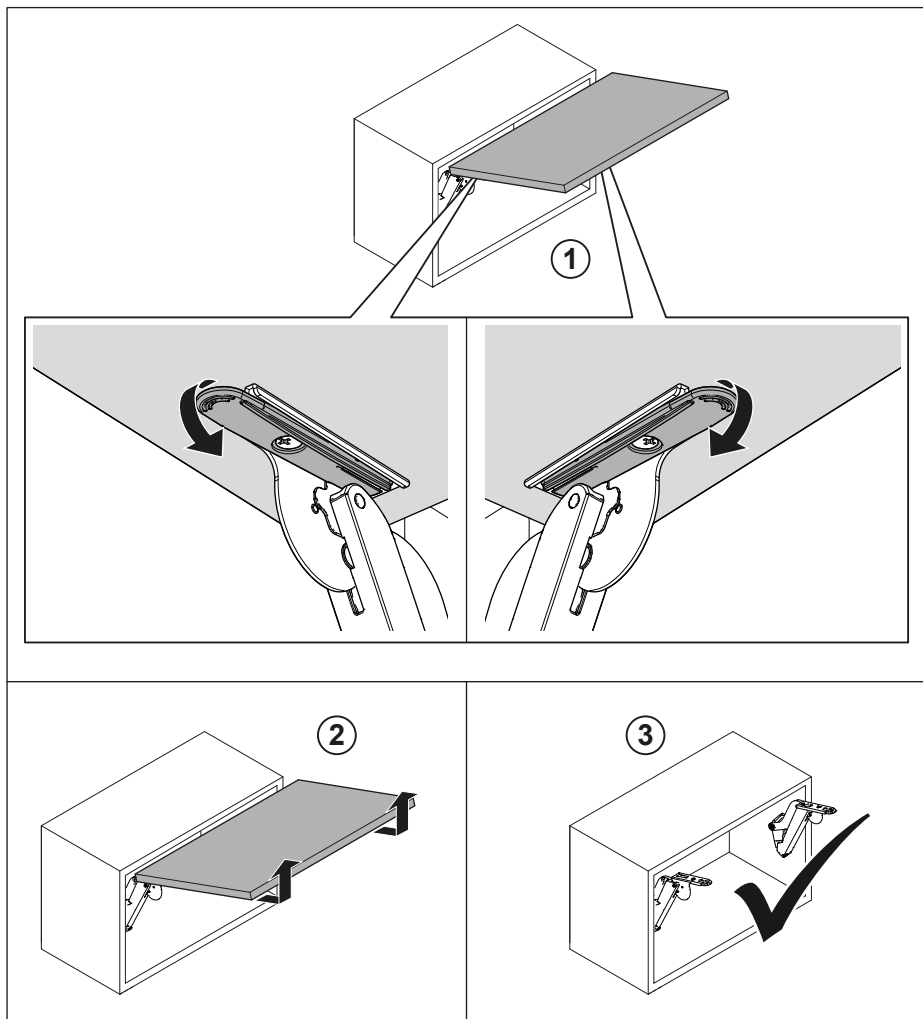

732.23.206

HDE 05.08.2019

GABARITO DE FURAÇÃO

IMPRIMA O DOCUMENTO NO TAMANHO ATUAL SEM REDIMENSIONÁ-LO.
Após a impressão, meça a escala para checar se está correta.

IMPRIMA O DOCUMENTO NO TAMANHO ATUAL SEM REDIMENSIONÁ-LO.
Após a impressão, meça a escala para checar se está correta.

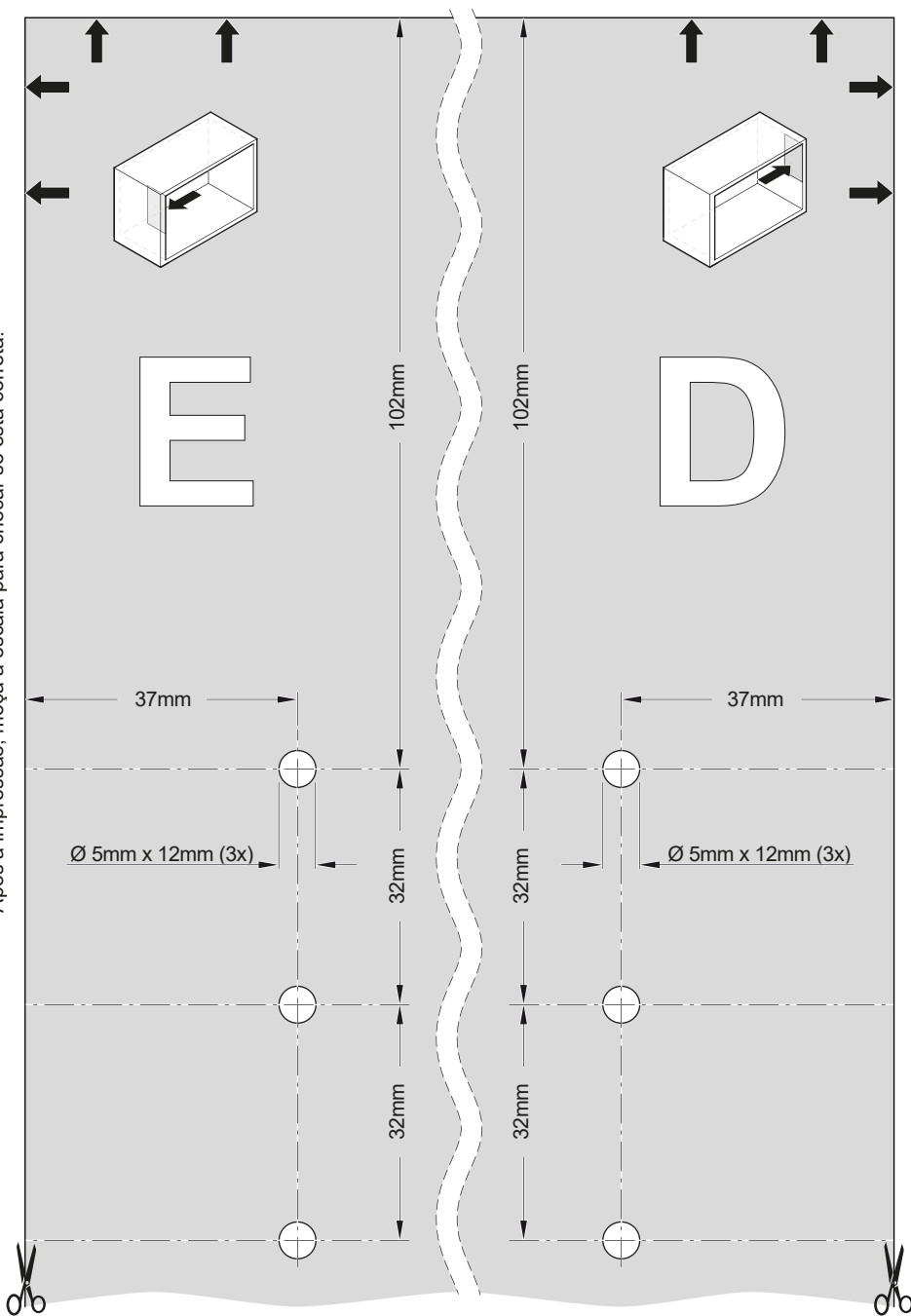

Elaboração:

© 2019 by Häfele GmbH & Co KG
Adolf-Häfele-Str. 1 · D-72202 Nagold · www.hafele.com

Suporte Local:

Häfele Brasil Ltda.
Rodovia João Leopoldo Jacomel, 4459 – Conjuntos 6 e 7
83304-000 | Jd Primavera | Piraquara | PR
Tel: +55 (41) 3034-8150 | Fax: +55 (41) 3034 8152
www.hafele.com.br